

Polaris Pen Kits Assembly Instructions

Required Accessories

- Pen Mandrel
- 2 piece Polaris bushing set
- 3/8"mm drill bit
- 2 part epoxy glue

Preparing the blanks

- Cut 3/4" to 5/8" square blank to the size of the brass tube (add 1/16" for trimming)
- Drill a 3/8" centre hole lengthwise through the blank.
- Spread the glue over the tube. Insert the tube into the blank with a twisting motion to spread the glue evenly inside. Centre the tube lengthwise in the blank
- When the glue dries, use a universal squaring jig or a belt/disc sander to square the ends.
- Trim the wood down, flush to the brass tube.

Diagram B - Turning the Blank

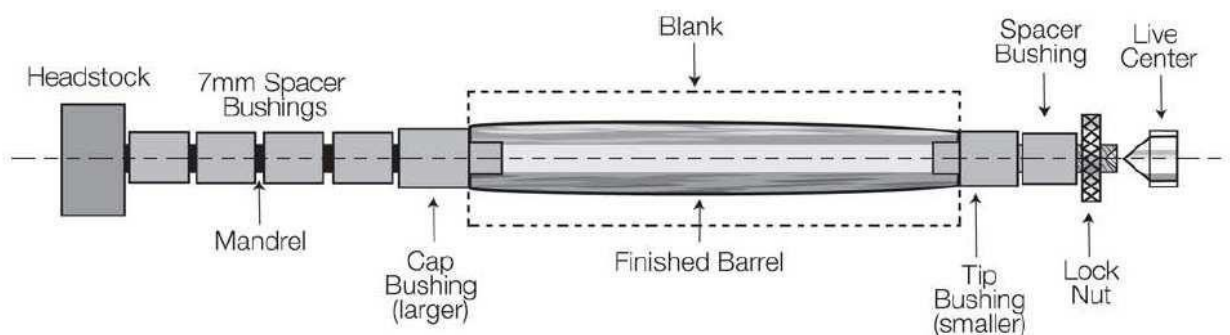

Turning the Blanks (see Diagram B)

- Mount 7mm spacer bushing on the mandrel, followed by the tip bushing; wide end first. Insert the blank. Follow with the cap bushing; narrow end first. Mount spacer bushing to fill the space to the threads on the mandrel. Screw on the knurled nut hand tight. Bring the tailstock in snug to the mandrel and tighten the knurled nut for turning. Do not overtighten the knurled nut, it may damage the mandrel.
- Turn the blank down close to the bushings. Follow with abrasives until the barrel diameters are flush with the bushings.
- Finish with your choice of polish.

Diagram A - Pen Parts

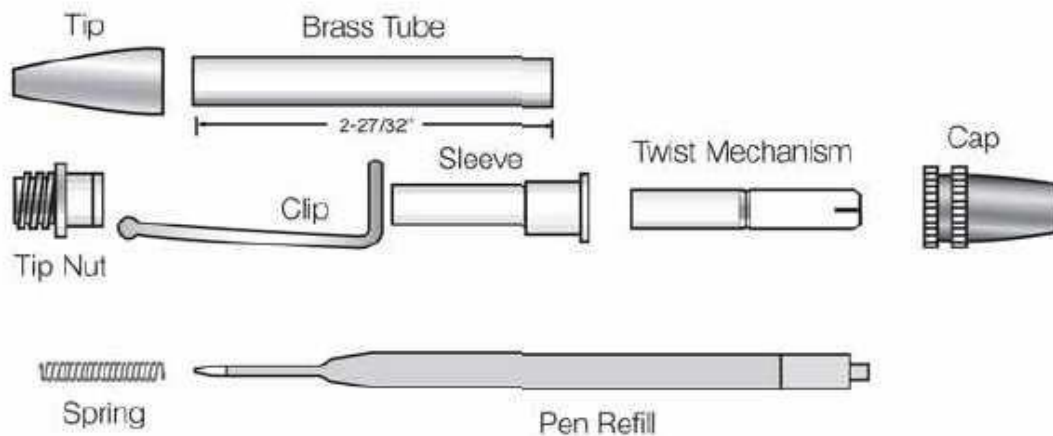

Assembly (Line up finished parts according to Diagram A)

- Insert the tip nut, recessed end in first, into the narrow end(tip) of the barrel and press to the shoulder.
- Insert the sleeve into the clip. Press the narrow end of the sleeve into the opposite end of the barrel

- Insert the twist mechanism, brass end first into the opening at the sleeve
- Press the mechanism in slowly until you feel it stop, which should leave 11/16" of the chrome remaining exposed.
- Test that the mechanism is spinning freely back and forth.
- Insert the refill with the spring over it, back end into the opening at the tip end. Thread the tip over the nut.
- Insert the cap assembly over the exposed end of the mechanism.
- The pen operates by twisting the cap to extend or retract the refill.

GreenVill Crafts